

NDV-5702-A Fixed dome 2MP HDR 3.4-10.2mm

FLEXIDOME indoor 5100i



- ▶ 1080p60 for highly detailed images
- ▶ Starlight camera technology with excellent low-light performance
- ▶ IVA Pro brings highly reliable deep-learning based detection of persons and vehicles to scenes ranging from sterile zones to crowded and congested
- ▶ High Dynamic Range to see every detail in both bright and dark areas of the scene

The camera is a versatile and professional surveillance camera for indoor monitoring. It delivers exceptional image quality, starlight performance and High Dynamic Range at resolution HD 1080p for highly detailed image for demanding security and surveillance network requirements.

Built-in Intelligent Video Analytics Pro (IVA Pro) enriches full situational awareness and triggers relevant alerts.

The camera offers a 1/2.8" sensor and HDR technology at HD 1080p resolution that provides high performance in extreme low light environments. The modular structure design uses a click and rotate mechanism on mounting plate or base that requires no hardware to secure the camera to housing for fast installation, including compatibility with various mounting options.

Functions

H.265 high-efficiency video encoding

The camera is designed on the most efficient and powerful H.264 and H.265/HEVC encoding platform. The camera is capable of delivering high-quality and high-resolution video with very low network load. With a doubling of encoding efficiency, H.265 has become the new compression standard of choice for IP video surveillance systems.

Intelligent Video Analytics Pro (IVA Pro)

The camera comes with the IVA Pro Buildings Pack pre-installed and brings highly reliable deep-learning based detection and tracking of persons and vehicles to scenes ranging from sterile zones to crowded and

congested. Being extremely resistant to false triggers caused by challenging environments with rain, wind (moving trees), snow, hail, and water reflections as well as shadows and bugs, it reliably detects, tracks, and classifies objects. A smart set of alarm and counter rules allows to alert you when predefined alarms are triggered, and to forensically search with high efficiency through recordings. Configuration effort is minimized and made easy by removing the need for calibration.

Optionally other packs can be licensed to optimize the camera analytics for specific enterprise use-cases with the IVA Pro Perimeter Pack or IVA Pro Traffic Pack.

Two-way audio

Two-way audio allows the operator to communicate with visitors or intruders via an external audio line input and output. By using the external microphone, audio detection can be used to generate alarms to alert the security operator quicker and act more proactively.

DORI coverage

DORI (Detect, Observe, Recognize, Identify) is a standard system (EN-62676-4) for defining the ability of a person viewing the video to distinguish persons or objects within a covered area. The maximum distance at which a camera/lens combination can meet these criteria is shown below:

2 MP camera with 3.4-10.2 mm lens*

DORI	DORI definition	Distance 10.2 mm / 3.4 mm	Horizontal width
Detect	25 px/m (8 px/ft)	31 m / 138 m (102 ft / 453 ft)	77 m (252 ft)
Observe	63 px/m (19 px/ft)	12 m / 55 m (39 ft / 180 ft)	30 m (100 ft)
Recognize	125 px/m (38 px/ft)	6 m / 28 m (20 ft / 92 ft)	15 m (50 ft)
Identify	250 px/m (76 px/ft)	3 m / 14 m (10 ft / 46 ft)	8 m (25 ft)

*The numbers in this table do not reflect IVA distances. For IVA distances, refer to the lens calculator / Bosch IP video design tool.

Scene modes

Multiple configurable modes are provided with the best settings for a variety of applications. In one click fully optimized image settings can be selected to suit the conditions. Different scene modes can be selected for different situations such as sodium lighting, fast moving objects, or dark environments.

Resists rain, dust, and tampering with reliable operation across a wide temperature range

The camera is suitable for indoor usage. The camera can operate in a wide ambient temperature range between -20 °C to +50 °C (-4 °F to +122 °F). The robust design of the camera is rated to IP54 and IK10 standards, safeguarding the camera against rain and dust while also offering protection against vandalism and tampering.

Easy installation

The mechanical design follows the Bosch installation philosophy by using an installation SMB and easy cable management.

Power can be supplied via Power-over-Ethernet. With this configuration, only a single cable connection is required to view, power, and control the camera. Using PoE makes installation easier and more cost effective, as cameras do not require a local power source.

For trouble-free network cabling, the camera supports Auto-MDIX which allows the use of straight or cross-over cables.

Data security

Special measures have been put in place to ensure the highest level of security for device access and data transport. The three-level password protection with security recommendations allows users to customize device access. Web browser access can be protected using HTTPS and firmware updates can also be protected with authenticated secure uploads. The cameras have built-in Secure Element (SE) hardware

providing main Trusted Platform Module (TPM) functionality to ensure the highest levels of data security and privacy protection. Together with Public Key Infrastructure (PKI) support, superior protection from malicious attacks is guaranteed. With future firmware updates, it will also support RSA encryption key lengths of up to 4096 bits, ensuring data safety beyond 2030. 802.1x network authentication with EAP/TLS will also be added. The advanced certificate handling offers:

- Bosch origin device certificate pre-installed
- Self-signed unique certificates automatically created when required
- Client and server certificates for authentication
- Client certificates for proof of authenticity
- Certificates with encrypted private keys

Edge recording

Insert a memory card into the card slot to store up to 2 TB of local alarm recording. Pre-alarm recording in RAM reduces recording bandwidth on the network, and extends the effective life of the memory card. It has advanced edge recording providing a reliable storage solution possible due to the combination of these functions:

- Industrial SD card support allows for extreme lifetime
- Health monitoring of industrial SD cards provide early service indications.

High Dynamic Range

The camera has High Dynamic Range. This is based on a multiple-exposure process that captures more details in the highlights and in the shadows even in the same scene. The result is that you can easily distinguish objects and features, for example, faces with bright backlight.

The actual dynamic range of the camera is measured using Opto-Electronic Conversion Function (OECF) analysis according to IEC 62676 Part 5. This method is used to provide standardized measurements, which can be used to compare different cameras.

Automatic image rotation

The integrated gyro/accelerometer sensor automatically corrects the image orientation in steps of 90° if the camera is mounted at right angles or upside down. The sensor image can also be rotated manually through steps of 90°.

To efficiently capture details in long hallways without loss of resolution, mount the camera at right angles. The image is displayed upright at full resolution on your monitor.

System Integration and ONVIF conformance

The camera conforms to the ONVIF Profile S, ONVIF Profile G, and ONVIF Profile T specifications. For H.265 configuration, the camera supports Media Service 2, which is part of ONVIF Profile T. Compliance with these standards guarantees interoperability between network video products

regardless of manufacturer. Third-party integrators can easily access the internal feature set of the camera for integration into large projects. Visit the Bosch Integration Partner Program (IPP) website (ipp.boschsecurity.com) for more information.

Modular accessories

A full line of modular accessories is available, which allows a consistent design across different cameras and a wide range of installation possibilities. Available options include wall or pipe mount, a surveillance cabinet with power and fiber optic options, and an in-ceiling mounting kit.

Cloud-based services

The camera supports time-based or alarm-based JPEG posting to four different accounts. These accounts can address FTP servers or cloud-based storage facilities (for example, Dropbox). Video clips or JPEG images can also be exported to these accounts. Alarms can be set up to trigger an e-mail or SMS notification so you are always aware of abnormal events.

Bosch Remote Portal

With the secure cloud infrastructure, Bosch Remote Portal, you can manage your connected Bosch devices. From the Bosch Remote Portal you can:

- Complete initial configuration of your connected Bosch devices (online or offline).
- Update firmware for single or multiple devices.
- Manage certificates.
- Monitor the health of your connected Bosch devices.

Project Assistant app

As the camera is equipped with a USB-C port for a wireless USB dongle (sold separately, available Q1 2023), the installer can easily perform the initial configuration wirelessly. Using a mobile device with the Bosch Project Assistant app, you can do initial set-up and lens zoom-focus to find the right scene. Simply connect the wireless USB dongle and go to the Bosch Project Assistant app, available for iOS, Windows, or Android.

Easy installation

The mechanical design follows the Bosch installation philosophy by using an installation mount plate and easy cable management. Power can be supplied via Power-over-Ethernet. With this configuration, only a single cable connection is required to view, power, and control the camera. Using PoE makes installation easier and more cost effective, as cameras do not require a local power source.

Standard	Type
	CFR 47 FCC part 15 (Class B) ICES-003 (Class B) VCCI CISPR 32 AS/NZS CISPR 32
Immunity	EN 50121-4 EN 50130-4
Environmental	EN 50130-5, Class II EN IEC 63000 RoHS EU, 2011/65/EU and 2015/863/EU WEEE EU, 2012/19/EU
Safety	EN 62368-1 IEC 62368-1 UL 62368-1
Image performance	IEC 62676-5
Impact protection	EN 62262 (IK10): 2002
Ingress protection	EN 60529 (IP54)
ONVIF conformance	EN 50132-5-2, EN 62676-2
Marks	CE, FCC, UL, WEEE, RCM, VCCI, UKCA, China RoHS, BIS
Compliance	NDA compliant

Installation/configuration notes

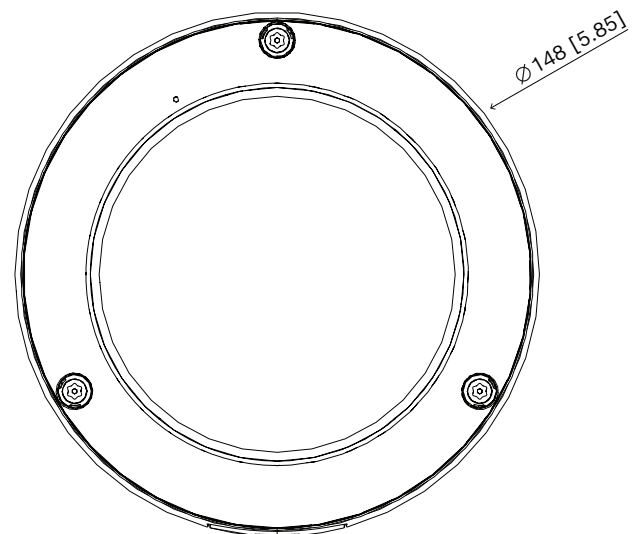

Regulatory information

Standard	Type
Emission	EN 55032 (Class B)

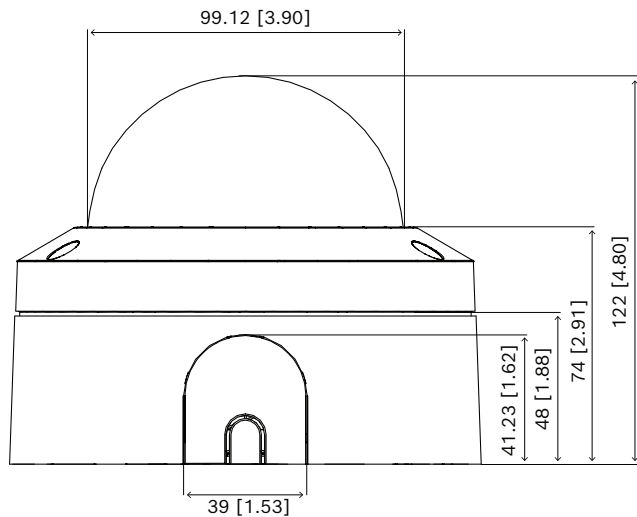

Dimensions in mm (inch)

Parts included

Quantity	Component
1	FLEXIDOME indoor 5100i - 2 MP camera
1	T-20 security Torx Allen key
1	4-pin terminal block
1	Adapter plate for cable conduit (Ø 3/4" / M25)
1	Adapter plate for cable conduit (Ø 1/2" / M20)
1	RJ45 guider
1	Mount plate
1	Safety information
1	Quick installation guide

Technical specifications

Electrical

Input voltage (DC)	48 VDC nominal
Power consumption PoE (W) (typical – maximum)	4.8 W – 6 W
PoE input	PoE IEEE 802.3af Type 1, Class 3

Sensor

Total sensor pixels (MP)	2 MP
Sensor type	1/2.8 inch CMOS
Effective pixels (H x V px)	1920 px x 1080 px

Optical

Lens type	3.4 to 10.2 mm
F-stop	1.6
Iris control	P-iris
IR corrected	Yes
Day / Night	Switchable IR-cut filter
Zoom/focus control	Motorized
Field of View wide (°)	57° – 102°
Field of View tele (°)	18° – 31°

Video functions

Day/night modes	Auto (adjustable switch points); Color; Monochrome
Camera functionality	Mirror image; Rotation 90°; Rotation 180°; Flip image; Geolocation; Rotation 270° including upright mode; Backlight compensation (BLC); Sharpness enhancement; Pixel counter; Saturation; Brightness; Video watermarking; Display stamping; Location; Electronic image stabilization (gyro-based)
White balance (K)	2500 K – 10000 K
White balance modes	Basic; Standard; Sodium vapor; Manual mode; Hold mode; 3 automatic modes
Shutter modes	Automatic Electronic Shutter (AES); 1/25 min; 1/15.000 max; Default shutter
Number of privacy masks	8
Scene modes with scheduler	Multiple default modes
Minimum illumination in color (lx) (sensitivity measured according to IEC 62676 Part 5)	0.0210 lx
Minimum illumination in monochrome (lx) (sensitivity measured according to IEC 62676 Part 5)	0.0040 lx
Wide Dynamic Range (WDR) (dB)	144 dB

Measured according to IEC 62676 Part 5 (dB)	105 dB
---	--------

Video streaming

Video compression	H.264 (ISO/IEC 14496-10); M-JPEG; H.265/HEVC
Number of encoder output streams	Multiple configurable streams in H.265; Configurable framerate and bandwidth; Region of Interest (ROI)
Camera processing latency	120 ms - 340 ms
GOP structure	IP; IBP; IBBP
Frame rate (fps)	1 fps – 60 fps
Video stream signal-to-noise ratio (dB)	>55 dB
Resolution	1920 x 1080; 1280 x 720; 768 x 432; 640 x 480; 1536 x 864; 720 x 480

Video content analysis

Analysis type	Intelligent Video Analytics Pro Buildings Pack
Alarm triggers	Any object; Object in field; Line crossing; Enter / leave field; Loitering; Follow route; Counting; Occupancy; Condition change; Similarity search; Objects stopping or starting to move
Object filters	Duration; Size; Aspect ratio; Direction; Color; Object classes (2)
Object classes	Person; Vehicle
Audio detection	Detection of audio to generate an alarm
Supported analytics	IVA Pro Perimeter Pack (license); IVA Pro Traffic Pack (license)

Inputs and outputs

Audio line in	0.6 Vrms max, 10 kOhm typical
Audio line out	1.0 Vrms at 10 kOhm typical
Ethernet	Shielded RJ45

Capacity

Number of RJ45 connections	1
----------------------------	---

Connectivity

Number of USB ports	1 (USB 2.0 Type C, for use with wireless USB dongle for setup and commissioning, sold separately)
---------------------	---

Audio

Audio input	Line-in
Audio output	Line-out
Compression and sampling rate	G.711 8 kHz; L16 16 kHz; AAC-LC 80kbps 16 kHz; AAC-LC 48kbps 16 kHz
Minimum signal-to-noise ratio (dB)	50 dB
Audio streaming	Full duplex; Half duplex

Storage

Internal RAM	5 s pre-alarm recording
Memory card slot	Micro SDHC; Micro SDXC (a memory card of Class 6 or higher is recommended for HD recording)
Memory card capacity (GB)	32 GB for Micro SDHC; 2 TB for Micro SDXC
Industrial SD cards	Extreme lifetime and health monitoring support that provides early service indication (if supported by the SD card)
Recording mode	Continuous (ring); Scheduled; Alarm; Event

Data security

Crypto coprocessor (TPM)	RSA 2048 bit; AES/CBC 256 bit; RSA 4096; ECDSA 256 bit
PKI	X.509 certificates
End-to-end encryption	Full end-to-end with supported VMS
Encryption	TLS 1.2; AES 256; AES 128; TLS 1.3
Local storage encryption	XTS-AES
Video authentication	MD5; SHA-1; SHA-256; Checksum
Firmware protection	Signed firmware, secure boot

Firmware

Common Product Platform	CPP14
-------------------------	-------

Network

Ethernet type	10/100BASE-T; Auto-sensing; Full / half duplex
---------------	--

System integration

Protocols / standards	IPv4; IPv6; UDP; TCP; HTTP; HTTPS; RTP/RTCP; IGMP V2/V3; ICMP; ICMPv6; RTSP; FTP; ARP; DHCP; APIPA (Auto-IP, link local address); NTP (SNTP); SNMP (V1, MIBII); SNMP (V3, MIBII); 802.1x, EAP/TLS; DNS; DNSv6; DDNS (DynDNS.org, selfHOST.de, no-ip.com); SMTP; iSCSI; UPnP (SSDP); DiffServ (QoS); LLDP; SOAP; CHAP; Digest authentication
Conformity	ONVIF Profile S; ONVIF Profile G; ONVIF Profile T; Auto-MDIX; ONVIF Profile M

Mechanical

3-axis adjustment (pan / tilt / rotation)	355° / 85° / 350°
Dimension (Ø x H) (mm)	148 mm x 122 mm
Dimension (Ø x H) (in)	5.83 in x 4.8 in
Weight (g)	920 g
Weight (lb)	2.03 lb
Color	White, Black
Color in RAL	RAL 9003 Signal white, RAL 9017 Traffic black
Gyroscope	Yes
Bubble material	Polycarbonate, clear with anti-scratch coating
Material	Polycarbonate, re-paintable
Mounting type	Surface-mounted (mount plate included); 4-inch square junction box, single and double gang box, 1/4-inch 20 UNC screw thread
Conduit	3/4-inch NPT(M25) and 1/2 -inch NPT (M20) conduit side entry

Environmental

Operating temperature (°C)	-20 °C – 50 °C for continuous operation
Operating temperature (°F)	-4 °F – 122 °F for continuous operation
Cold start temperature (°C)	-20 °C
Cold start temperature (°F)	-4 °F
Storage temperature (°C)	-30 °C – 70 °C
Storage temperature (°F)	-22 °F – 158 °F
Operating relative humidity, non-condensing (%)	5% – 93%
Operating relative humidity, condensing (%)	5% – 100%
Storage relative humidity (%)	0% – 98%
Impact protection (EN 50102)	IK10
IP rating	IP54
Usage	Indoor
Sustainability	PVC-free
Country of origin	Thailand

Ordering information**NDV-5702-A Fixed dome 2MP HDR 3.4-10.2mm**

Professional IP fixed dome camera for indoor 60 fps surveillance with H.264/H.265 and IVA Pro Buildings Pack, 2 MP, IP54, IK10
NDAA compliant

Order number **NDV-5702-A | F.01U.394.427**

Accessories**NDA-5070-IC In-ceiling mount kit**

In-ceiling mount kit for FLEXIDOME indoor 5100i, FLEXIDOME indoor 5100i IR, FLEXIDOME outdoor 5100i, and FLEXIDOME outdoor 5100i IR

Order number **NDA-5070-IC | F.01U.401.739**

NDA-5070-PLEN In-ceiling plenum kit, 148mm

Plenum-rated in-ceiling mount kit for FLEXIDOME indoor 5100i, FLEXIDOME indoor 5100i IR, FLEXIDOME outdoor 5100i, and FLEXIDOME outdoor 5100i IR

Order number **NDA-5070-PLEN | F.01U.399.151**

NDA-5070-LWMT L shape wall mount for FLEXIDOME 5100i

L-shaped wall mount for FLEXIDOME indoor 5100i, FLEXIDOME indoor 5100i IR, FLEXIDOME outdoor 5100i, FLEXIDOME outdoor 5100i IR, and FLEXIDOME IP 3000i IR
Order number **NDA-5070-LWMT | F.01U.399.152**

NDA-5080-PIP Pendant interface plate, 148mm

Pendant interface plate for FLEXIDOME indoor 5100i, FLEXIDOME indoor 5100i IR, and FLEXIDOME panoramic 5100i IR
Order number **NDA-5080-PIP | F.01U.389.607**

NDA-5070-PC Paintable cover, FLEXIDOME 5100i, 4pcs

Paintable cover (4 pieces) for FLEXIDOME 5100i and FLEXIDOME 5100i IR
Order number **NDA-5070-PC | F.01U.399.153**

NDA-5070-CBL Bubble, clear for FLEXIDOME 5100i

Clear replacement bubble for FLEXIDOME indoor 5100i and FLEXIDOME outdoor 5100i
Order number **NDA-5070-CBL | F.01U.399.145**

NDA-5070-TBL Bubble, tinted for FLEXIDOME 5100i

Tinted bubble for FLEXIDOME indoor 5100i and FLEXIDOME outdoor 5100i
Order number **NDA-5070-TBL | F.01U.399.144**

NDA-MCSMB-03M Cable, SMB to BNC, 0.3m

0.3 m (1 ft) analog cable, SMB (female) to BNC (female) to connect camera to coaxial cable
Order number **NDA-MCSMB-03M | F.01U.399.128**

NDA-MCSMB-30M Cable, SMB to BNC, 3.0m

3 m (9 ft) analog cable, SMB (female) to BNC (female) to connect camera to coaxial cable
Order number **NDA-MCSMB-30M | F.01U.399.126**

NDA-U-CBB Conduit back box, 148mm

Outdoor conduit back box, 148mm, IP66 rated
Order number **NDA-U-CBB | F.01U.394.006**

NDA-U-CMT Corner mount adapter

Universal corner mount, white
Order number **NDA-U-CMT | F.01U.324.946**

NDA-U-PMAS Pole mount adapter small

Pole mount adapter small
Universal pole mount adapter, white; small.
Order number **NDA-U-PMAS | F.01U.324.943**

NDA-U-PMAL Pole mount adapter large

Universal pole mount adapter, white; large
Order number **NDA-U-PMAL | F.01U.324.944**

NDA-U-PSMB Pendant wall/ceiling mount SMB

Surface mount box (SMB) for wall mount or pipe mount.
Order number **NDA-U-PSMB | F.01U.324.942**

NDA-U-WMT Pendant wall mount

Universal wall mount for dome cameras, white
Order number **NDA-U-WMT | F.01U.324.939**

NDA-U-PMT Pendant pipe mount, 12" (31cm)

Universal pipe mount for dome cameras, 31 cm, white
Order number **NDA-U-PMT | F.01U.324.940**

NDA-U-PMTE Pendant pipe extension, 20" (50cm)

Extension for universal pipe mount, 50 cm, white
Order number **NDA-U-PMTE | F.01U.324.941**

NDA-U-PMTG Pendant pipe mount, gang box

Universal pipe mount, compatible with gang box installation for fixed dome cameras only, white
Order number **NDA-U-PMTG | F.01U.358.359**

NDA-U-PMTS Pendant pipe mount, 4" (11 cm)

Universal pendant pipe mount for dome cameras, 11 cm (4"), white
Order number **NDA-U-PMTS | F.01U.385.046**

NDA-U-WMTG Pendant wall mount, gang box

Universal wall mount, compatible with gang box installation for fixed dome cameras only, white
Order number **NDA-U-WMTG | F.01U.358.358**

NPD-3001-WAP Portable installation tool

Bosch camera portable and wireless installation tool
Order number **NPD-3001-WAP | F.01U.353.329**

NPD-5001-POE Midspan, 15W, single port, AC in

Power-over-Ethernet midspan injector for use with PoE enabled cameras; 15.4 W, 1-port
Weight: 200 g (0.44 lb)
Order number **NPD-5001-POE | F.01U.305.288**

NPD-5004-POE Midspan, 4 port x 15W, AC in

Power-over-Ethernet midspan injector for use with PoE enabled cameras; 15.4 W, 4-ports
Weight: 620 g (1.4 lb)
Order number **NPD-5004-POE | F.01U.305.289**

MSD-064G IP SECURITY MICROSD CARD 64GB

64 GB industrial microSD card with health status monitoring
Order number **MSD-064G | F.01U.394.680**

MSD-128G IP SECURITY MICROSD CARD 128GB

128 GB industrial microSD card with health status monitoring
Order number **MSD-128G | F.01U.394.681**

MSD-256G IP SECURITY MICROSD CARD 256GB

256 GB industrial microSD card with health status monitoring
Order number **MSD-256G | F.01U.394.682**

MNT-ICP-FDC Drop ceiling support kit for FLEXIDOME

Suspension ceiling support kit for FLEXIDOME IP 2000/4000/5000/5100i/7000 (except RD series) and panoramic 5000/7000 series cameras
Order number **MNT-ICP-FDC | F.01U.316.129**

Represented by:

Europe, Middle East, Africa:
Bosch Security Systems B.V.
P.O. Box 80002
5600 JB Eindhoven, The Netherlands
Phone: + 31 40 2577 284
www.boschsecurity.com/xc/en/contact/
www.boschsecurity.com

Germany:
Bosch Sicherheitssysteme GmbH
Robert-Bosch-Ring 5
85630 Grasbrunn
Tel.: +49 (0)89 6290 0
Fax: +49 (0)89 6290 1020
de.securitysystems@bosch.com
www.boschsecurity.com

North America:
Bosch Security Systems, LLC
130 Perinton Parkway
Fairport, New York, 14450, USA
Phone: +1 800 289 0096
Fax: +1 585 223 9180
onlinehelp@us.bosch.com
www.boschsecurity.com

Asia-Pacific:
Robert Bosch (SEA) Pte Ltd, Security Systems
11 Bishan Street 21
Singapore 573943
Phone: +65 6571 2808
Fax: +65 6571 2699
www.boschsecurity.com/xc/en/contact/
www.boschsecurity.com